

**MOS**

MORE ON SIMPLICITY

# OUR STUDIO

# MOS

“ MOS grew from a simple yet complex idea: to design more on simplicity ”

MOS was founded in Barcelona in 2011. The leading forces behind MOS are two entrepreneurs, David Grifols and David Roselló, who have worked internationally in various design roles over the past 12 years.

MOS offers a wide range of design services, from industrial design to graphic design to interior design and product development. We have worked internationally.

## THE TEAM

The founding members David Grifols and David Roselló each bring their own speciality to MOS. David Grifols comes from a business management, operations and execution background. David Roselló brings creative expertise in product as well as graphic and visual design.

Both partners have degrees in Engineering of Industrial Design and Product Development.

MOS specializes in creating innovative designs to improve customer satisfaction and increase market value for brands.

## OUR PROMISE

Our fundamental promise is to give appropriate solutions to a variety of challenges, creating viable technological and economical projects while meeting customer needs.

At MOS, we consider design to be essential in every business project. This is why we are involved in all aspects of the process, from the creative and organizational to the technical, while collaborating with experts in other domains such as marketing, communications and engineering.

MOS has found his niche in the market, on the national and international level, by developing innovative, attractive, functional and feasible projects. At MOS, we are ready to make your ideas reality with innovation and dedication.

# OUR SERVICES

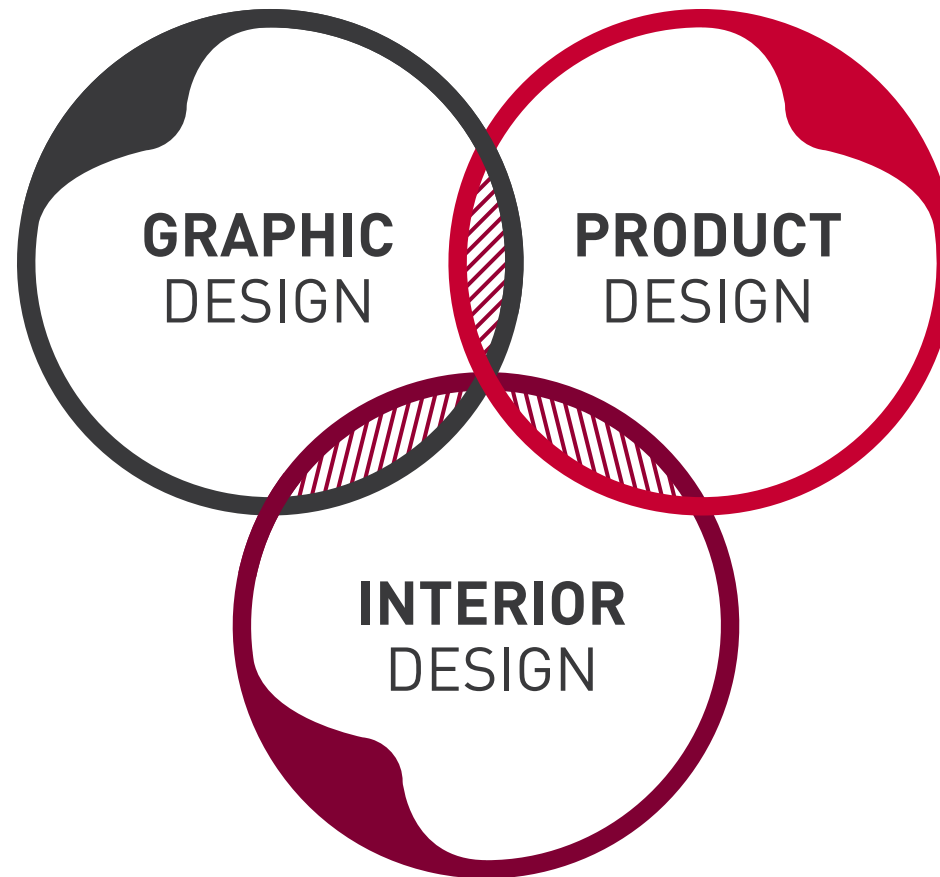

MOS offers a wide range of design services, from industrial design to graphic design to interior design and product development.

# OUR TEAM

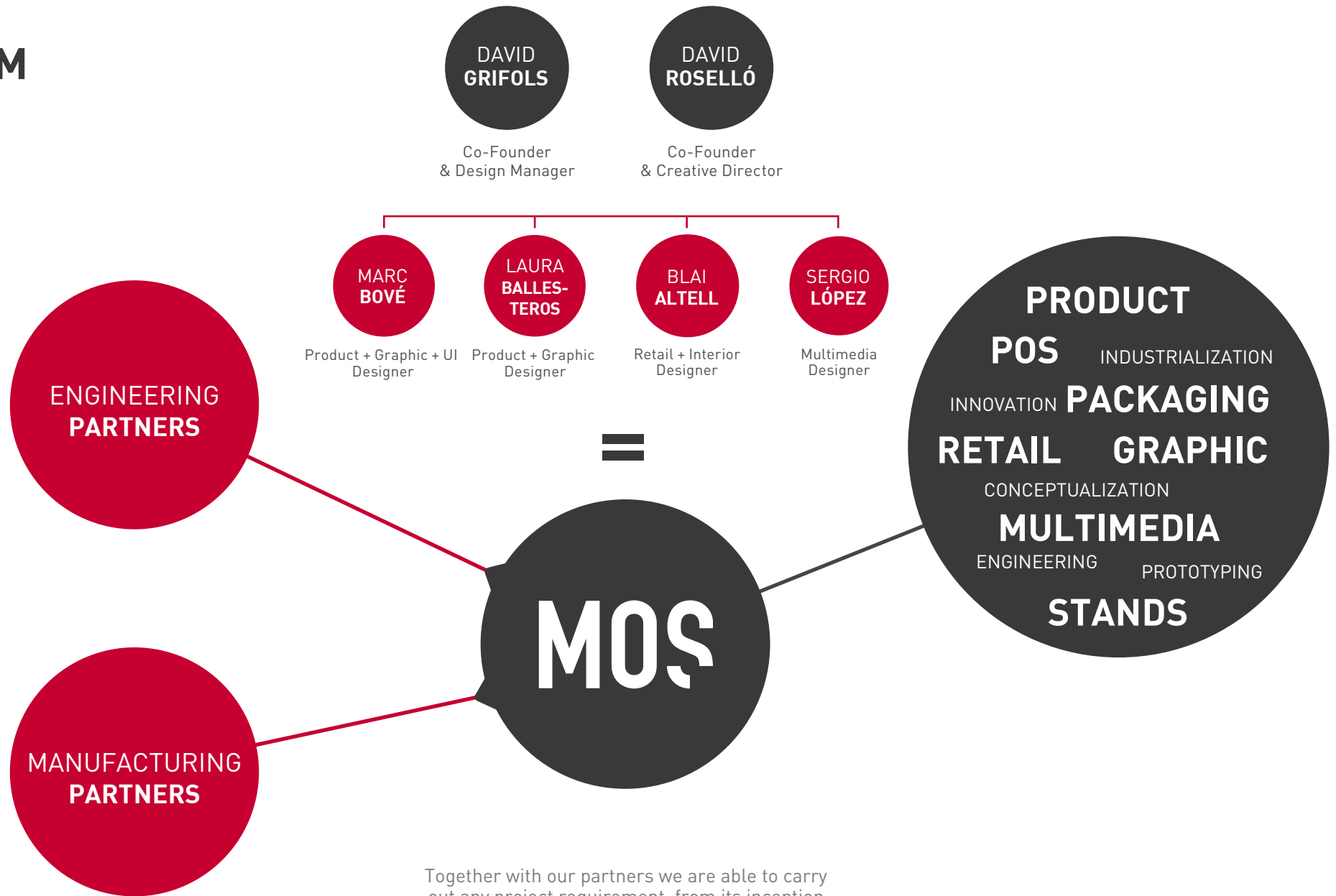

Together with our partners we are able to carry out any project requirement, from its inception to production.

# ENGINEERING PARTNERS

## ● AES Engineering

AES it's our trusted partner for projects related to automotive industry. With offices in Barcelona and Germany, AES provides a perfect engineering service to MOS.



[www.engineering-aes.com](http://www.engineering-aes.com)

## ● PLUMARTIS

Plumartis is our perfect partner when we need to take our projects into another step. With their trusted knowledge, they provide technical service to our designs, by planning for each project the best prepared internal technician.

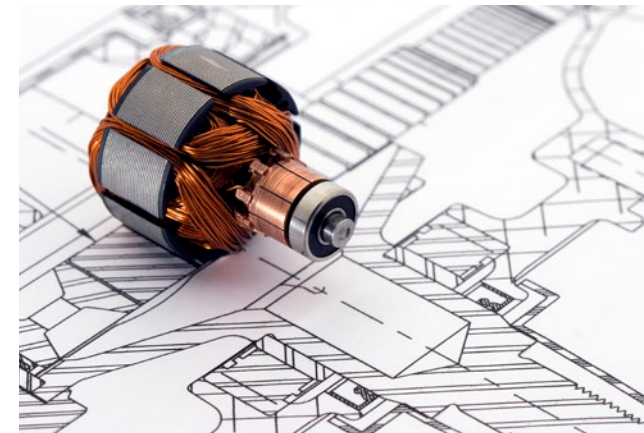

[www.plumartis.com](http://www.plumartis.com)

# MANUFACTURING PARTNERS

## ● CDI Creación y Diseño Ibense

We partner CDI since the beginnings. CDI is our trusted partner when it comes to Plastics and Metal work. CDI is based in Ibi (Alicante, Spain).

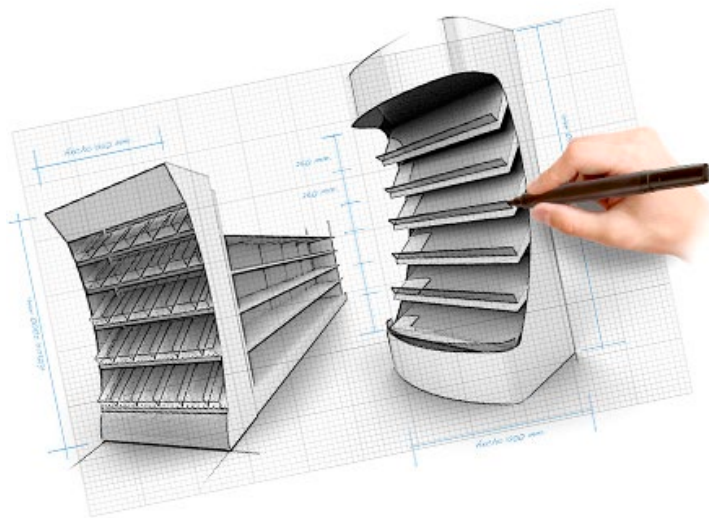

[www.cdi-ibense.com](http://www.cdi-ibense.com)

## ● FACTUM VERUS

Based in Barcelona, Factum Verus has been a partner of MOS for over 3 years. With a team of 7 professionals, Factum Verus gives support to all the POS made of cardboard. Together we guarantee a wide range of solutions always under an optimal perspective.



[www.factumverus.com](http://www.factumverus.com)

# OUR CLIENTS



GRIFOLS

SUNPLAST

PHILIPS



MyWay®

Haier



Midea



FLORY



gasN2



ESPINALER

ALVISA



celio\*

DIETOX.  
WE RESET YOUR BODY



# MOS DESIGN PROCESSES



# PRODUCT DESIGN PROCESS

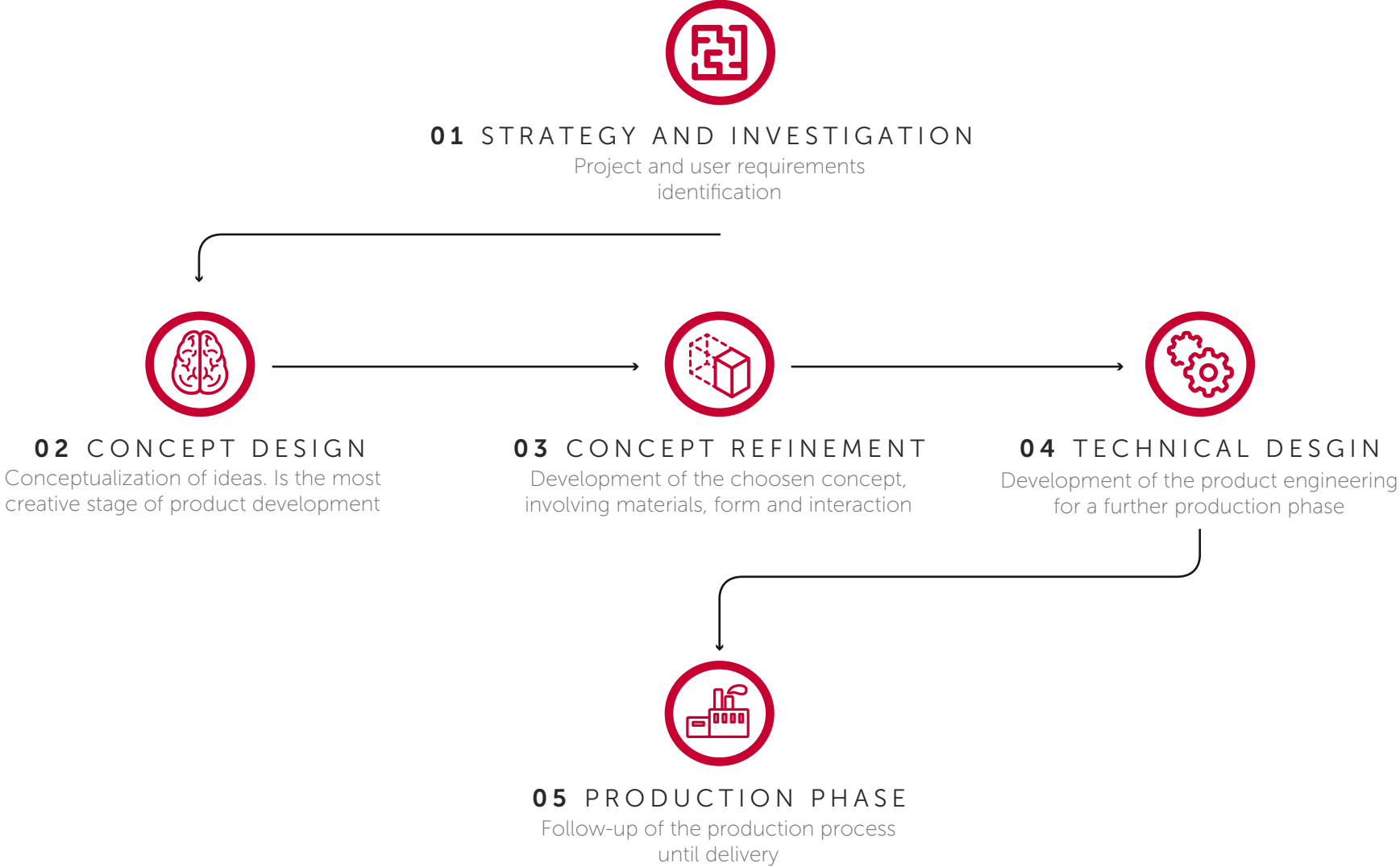

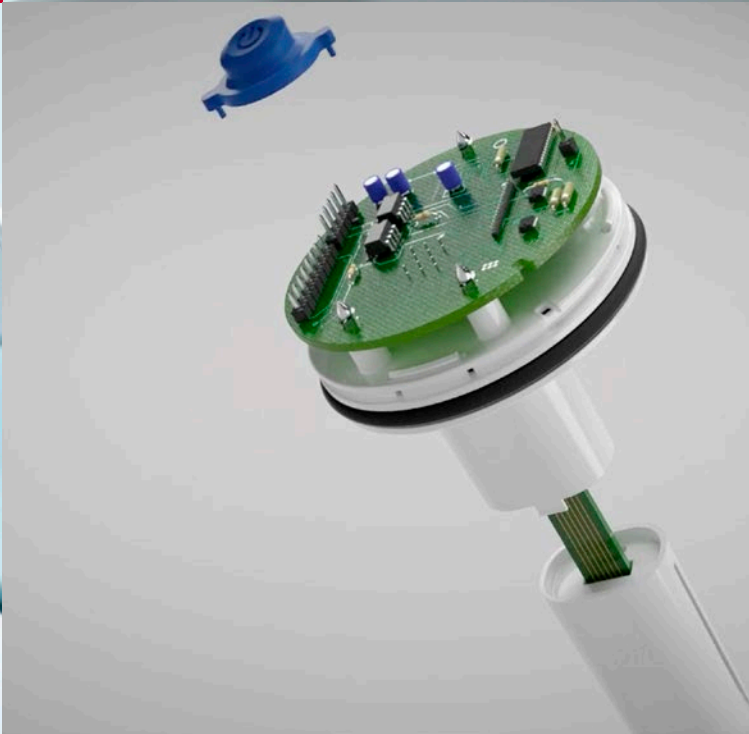
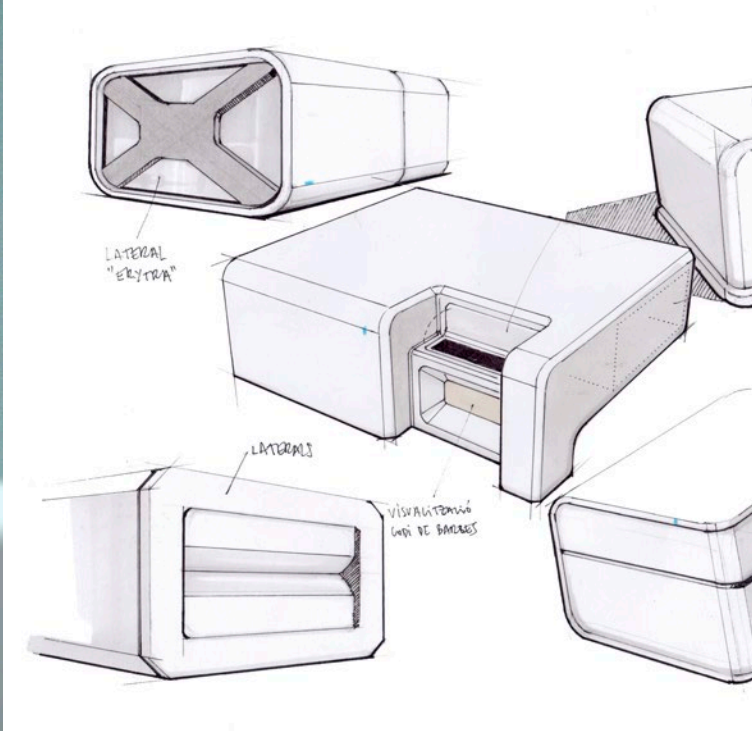

# PACKAGING DESIGN PROCESS

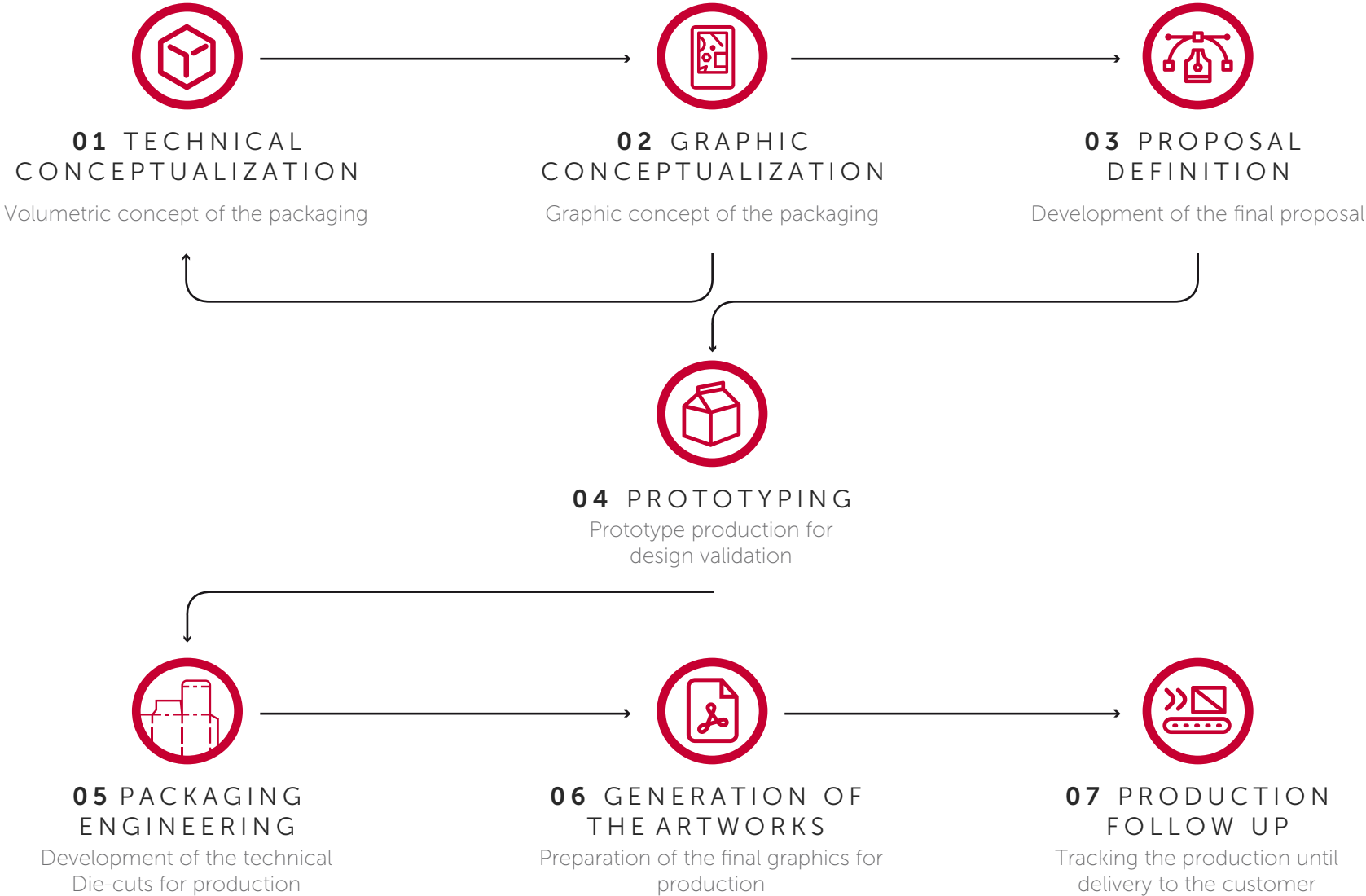





Lit-Control

CJ0025.00

Monitoring of urinary pH allows the control of frequent urologic pathology, and is particularly advisable in the prevention of renal lithiasis.

Lit-Control pH Meter device monitors urinary pH in a simple, quick and efficient way. Besides, the Lit-Control pH Up, Lit-Control pH Down, and Lit-Control pH Balance food supplements allow regulating the urinary pH levels according to the needs of each patient on self-management.

Manufactured by: **Devicare S.L.**  
Av. Can Domènec,  
Eureka Building (UAB Campus)  
08193 Cerdanyola del Vallès  
Barcelona, Spain  
+34 935 868 670  
www.devicare.com  
www.lit-control.com

Distributed by: **Laboratorio M4 Pharma S.L.**  
C. Marroc, 200,  
08019 Barcelona  
Spain  
+34 933 034 610  
www.m4pharma.com

Medical device for self-diagnosis and control urinary pH.

1. Hold the meter firmly and unscrew the used container.
2. Dispose of the container in an environmentally friendly manner.
3. Hold the meter firmly again and screw the new container.

Icons: Warning, No open flame, No heat, No fire, No smoking, No alcohol, No sharp objects, No magnets, No high voltage, No high pressure, No strong acids/bases, No strong oxidizers, No strong reducers, No strong irritants, No strong allergens, No strong sensitizers, No strong carcinogens, No strong mutagens, No strong teratogens, No strong reproductive toxins, No strong developmental toxins, No strong reproductive system toxins, No strong developmental system toxins.

5°C, 45°C

0 000000 000000



# BRANDING DESIGN PROCESS

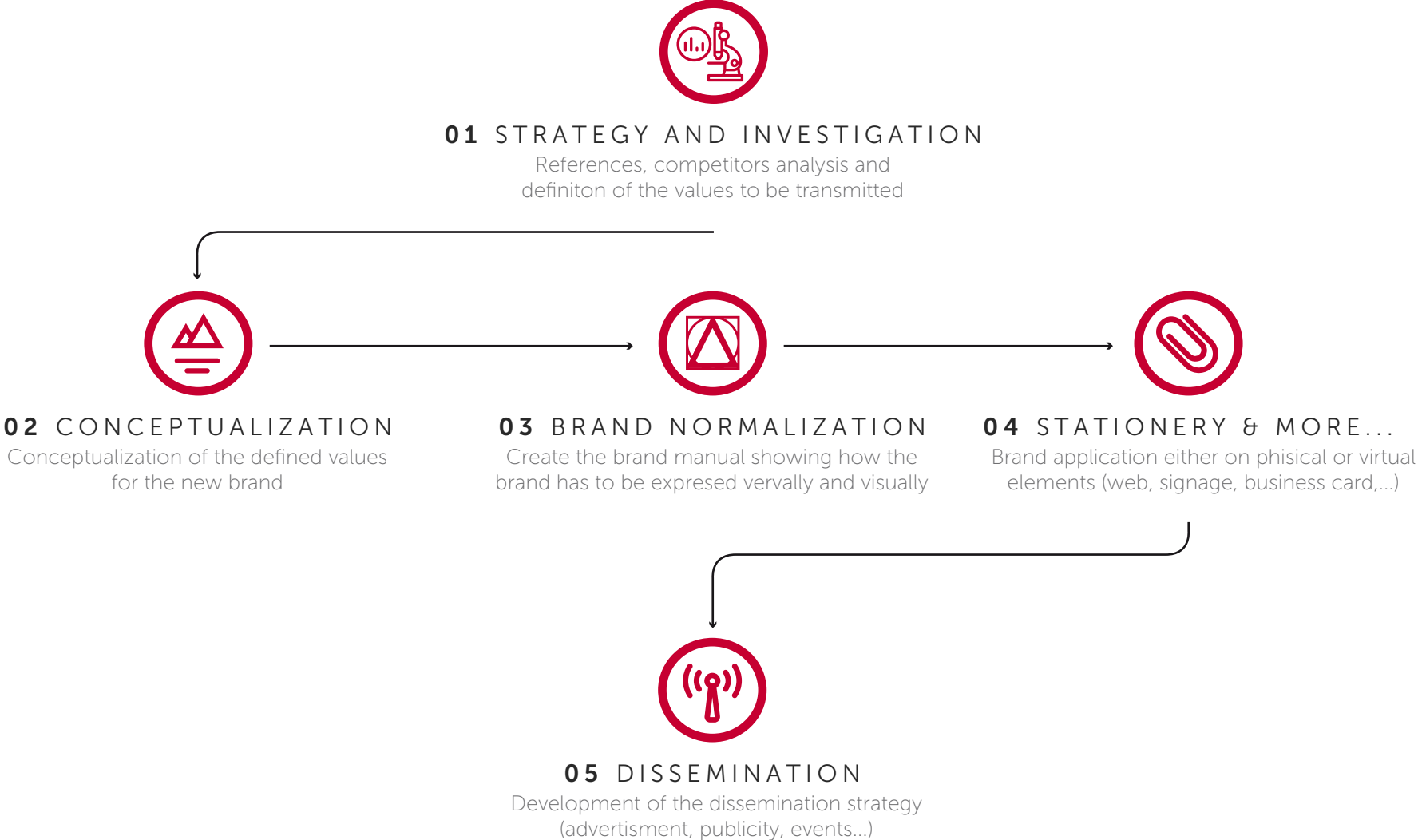



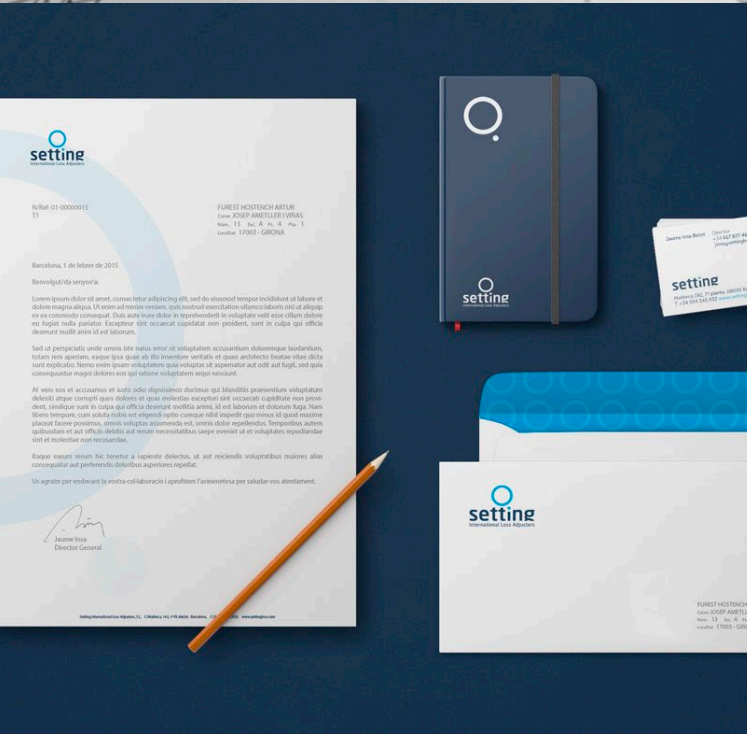
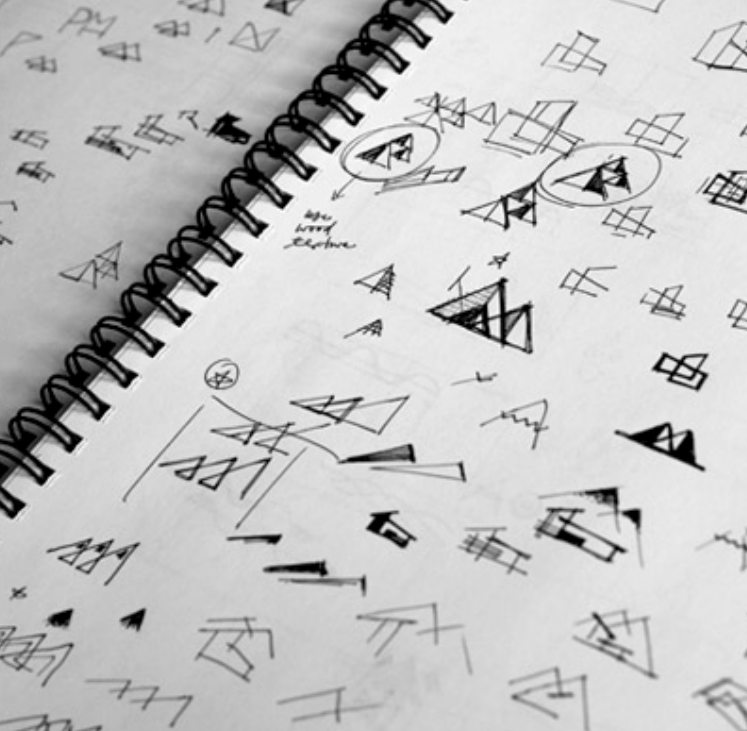

# UI & MULTIMEDIA DESIGN PROCESS

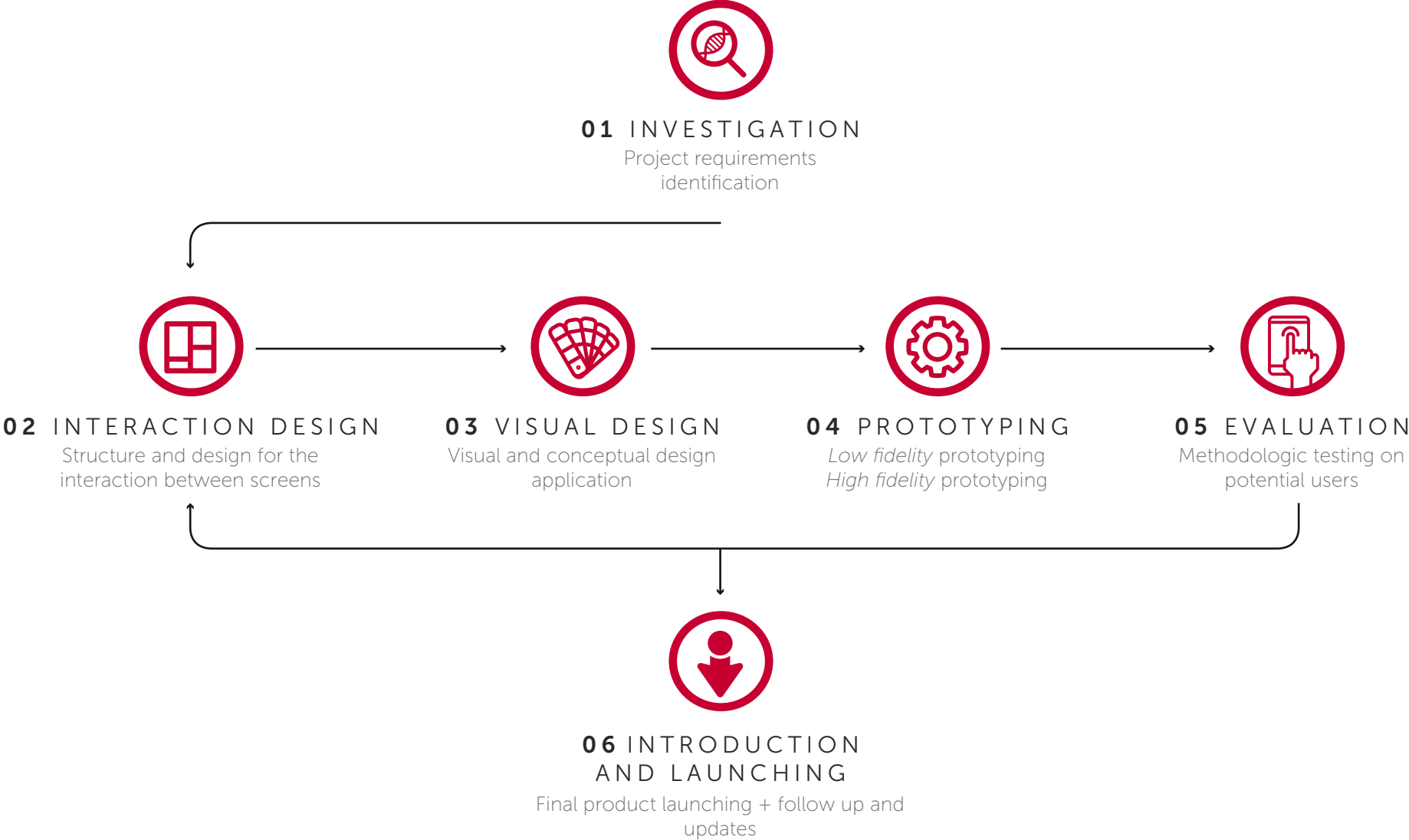



**Paso 2 | Encendido**

**Paso 3 | Calibrado**

**Paso 4 | Test**

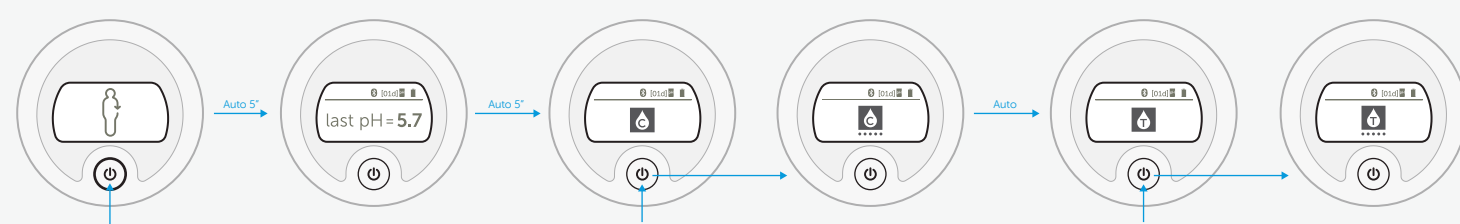



# RETAIL DESIGN PROCESS

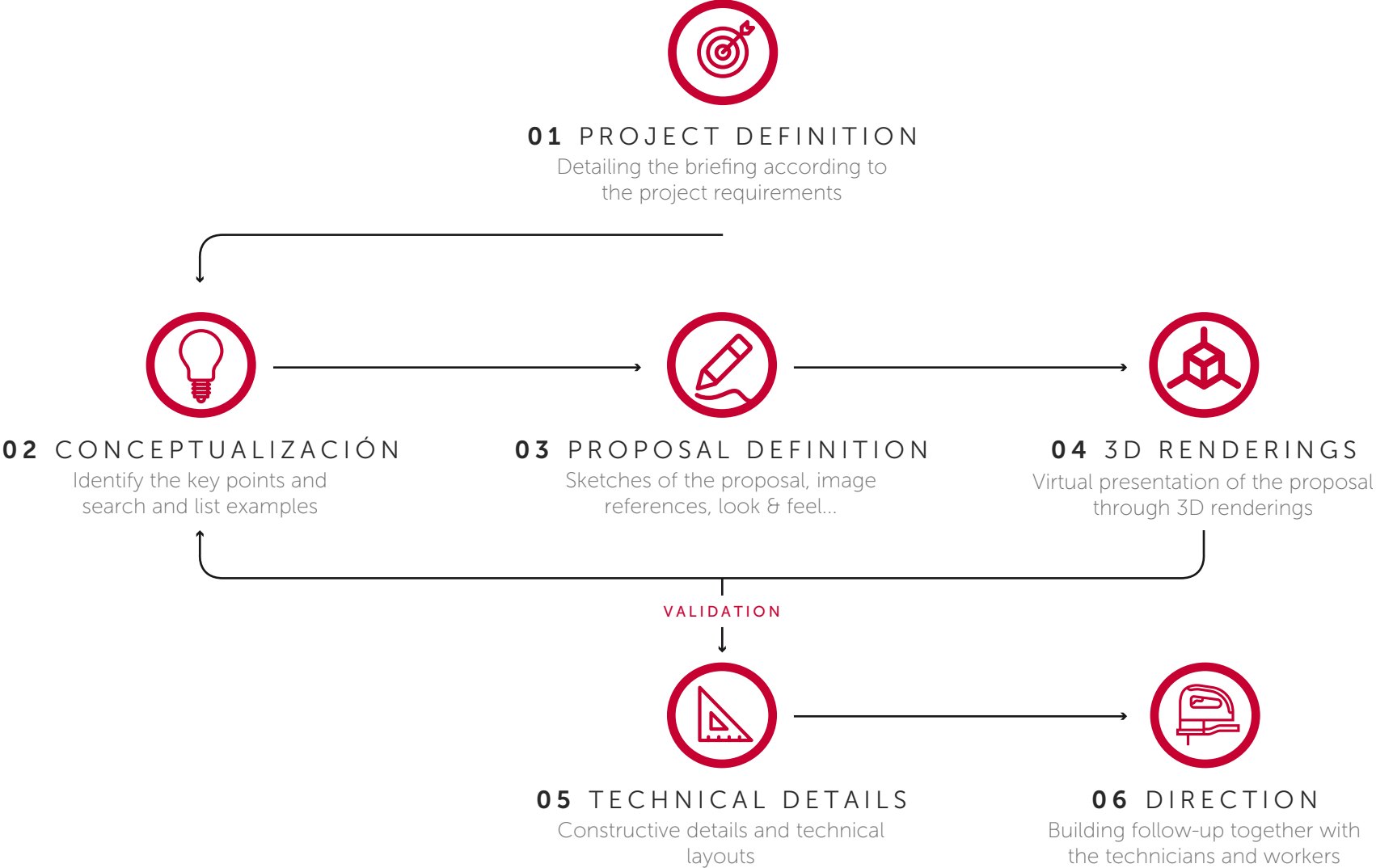



# POS DESIGN PROCESS



## 01 STRATEGY AND INVESTIGATION

Project and user requirements identification.  
Materials, products planogram...



## 02 TECHNICAL DEVELOPMENT

Volumetric study of the POS, defining its  
dimensions and structure



## 03 GRAPHIC DEVELOPMENT

Adapt the artworks with high resolution graphics for  
professional and massive production

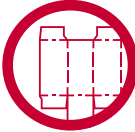

## 04 POS ENGINEERING

Die-cuts, laser cutting layouts, CAD-CAM for injection  
molding, plotting...



## 05 PROTOTYPING

Prototyping for testing capacity, stability,  
mounting, user interaction...

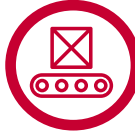

## 06 MANUFACTURING

Production follow-up together with our  
POS experts partners



## 07 STOCK & SHIPPING

MOS offers optional stocking and  
international shipping plans for big orders



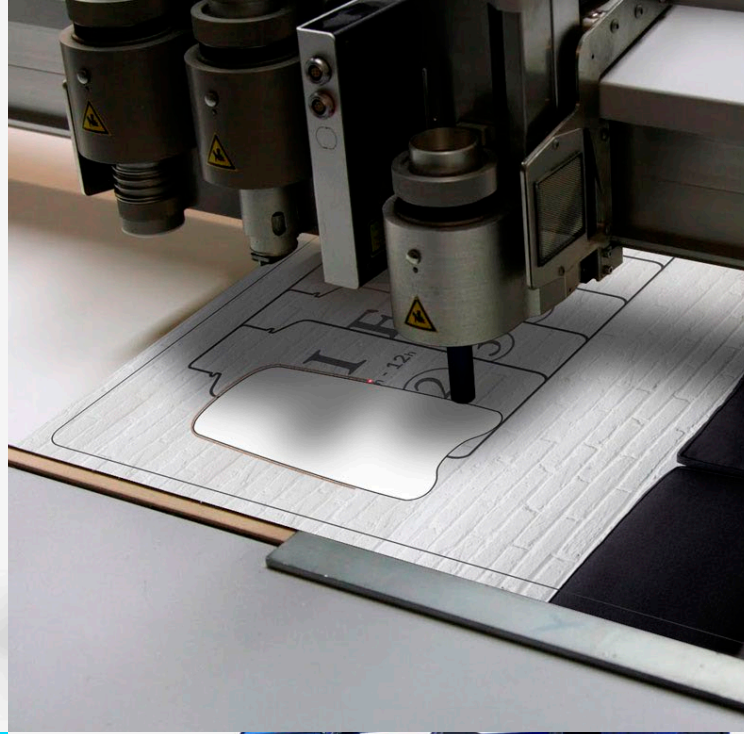

# MOS

**More On Simplicity**

C/ Anglesola 34, Local, 08014, Barcelona  
[+34] 933 155 102  
info@mosbcn.com

[mosbcn.com](http://mosbcn.com)